



FIRST ARTICLE INSPECTION REPORT



Part number: PP-FP0174		Version: B	
Description: Touch Screen Bezel			
Supplier: INSULFAB	PO:32385	Date: 09/12/2019	WHS

Number	Device	Target	Tolerance	Actual	Result
1	Eyes	RoHS ok		OK	PASS
2	Eyes	Clean		OK	PASS
3	Eyes	White PVC		OK	PASS
4	Eyes/Caliper	No scratches >3mm	+0	1 ON A-FACE	2 PASS
5	Radius gauge	R9.0	±0.75	R=9.0	PASS
6	Caliper	84.5	±0.75	84.64	PASS
7	Caliper	72.0	±0.75	72.06	PASS
8	Pin gauges	5X Ø4.0	±0.75	3.72	PASS
9	Caliper	55.5	±0.75	55.5	PASS
10	Caliper	6.4	±0.75	6.53	PASS
11	Caliper	12.4	±0.75	12.75	PASS
12	Radius gauge	R2.0	±0.75	R=1.5	PASS
13	Caliper	56.5	±0.75	56.32	PASS
14	Caliper	16.7	±0.75	16.84	PASS
15	Caliper	6.0	±0.75	5.99	PASS
16	Caliper	123.2	±0.75	123.47	PASS
17	Caliper	111.0	±0.75	111.02	PASS
18	Caliper	99.0	±0.75	98.7	PASS
19	??	A face		1 failed w/ Scratches	PASS
20	Caliper	2.00	±0.25	1.93	PASS

- NOTES:**
- ① 1. PARTS MUST BE RoHS COMPLIANT
 - ② 2. PART FORWARD FACE MUST BE CLEAN, FREE OF OIL, DEBRIS, AND MANUFACTURING ARTIFACTS
 - ③ 3. MATERIAL: White PVC
 - ④ 4. SURFACE TO BE FREE OF SCRATCHES OVER 3mm

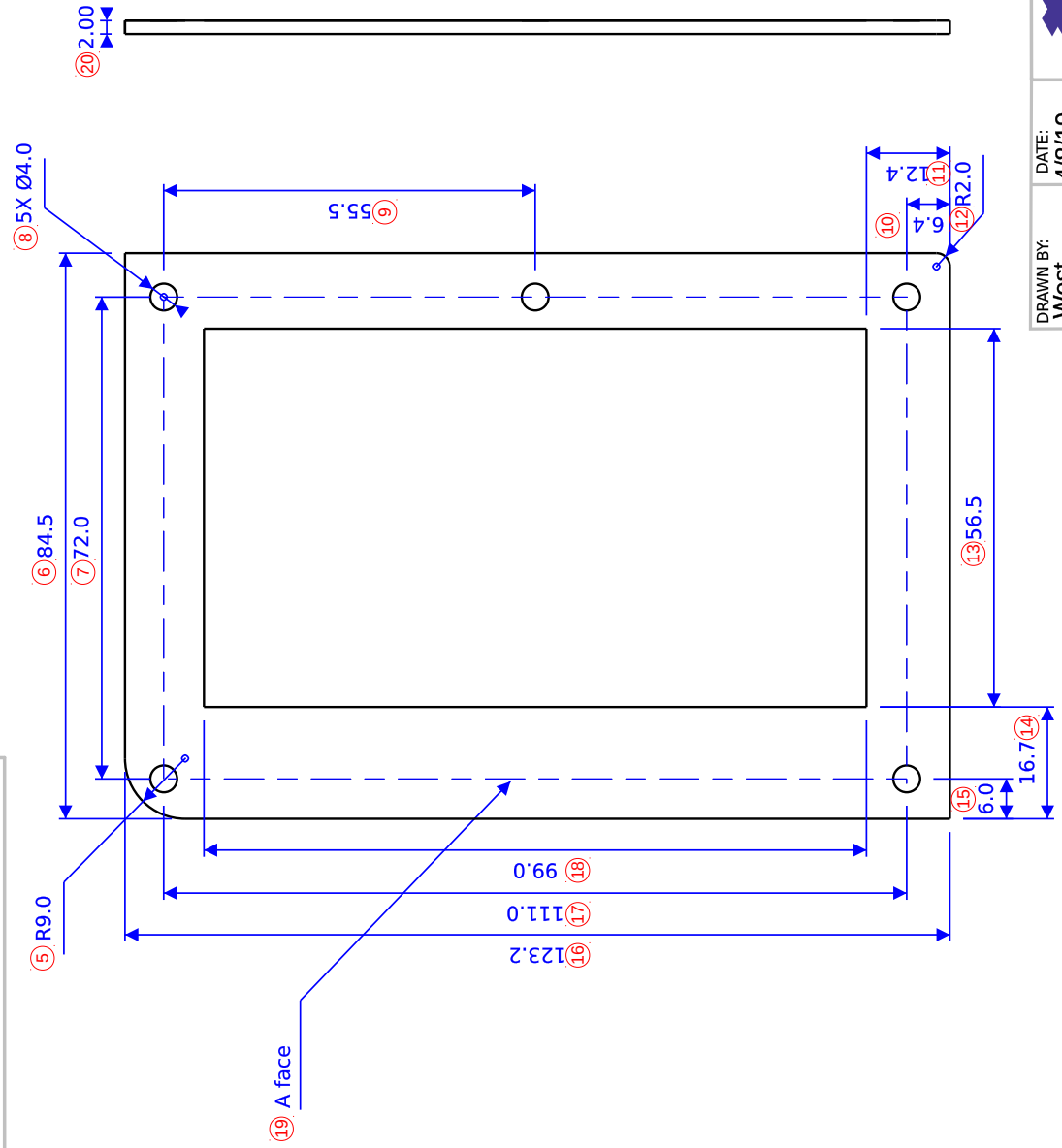

Rev	A	Notes	Date	Initial
	B	Add fifth hole to prevent bowing on assembly Change name to touchscreen bezel, 8/12/19 Change material to PVC	7/2/19	JW
DRAWN BY:		DATE:	TITLE	
West		4/8/19	touchscreen_bezel	
MATERIAL:		See notes	SIZE	DWG NO.
UNLESS OTHERWISE SPECIFIED DIMENSIONS ARE IN MILLIMETERS. TOLERANCES ARE:			A	PP-FP0174
DECIMALS		X: .75	SCALE	NA
ANGLES		X° ± 1°	DO NOT SCALE DRAWING	SHEET
X.X: .125		63		1 of 1
X.XX: .050				
X.XXX: .050				
BREAK EDGES 0.1/0.5				
FILLET RADIUS 0.1/0.5				



626 West 66th Street
 Loveland, Colorado 80538, USA
 Phone +1-970-377-1111
 www.alephobjects.com